

INSTRUMENTATION AND MEASUREMENTATION

PROJECT REPORT

STRESS METER



Submitted To:

Mr. Usman Ali

Submitted By:

Sajid Ali 081220-097

Qadeer Imdad 081120-001

Muhammad Husnain Shible 071020-196

Department of Electrical Engineering,
School of Science and Technology,
University of Management and Technology,
Lahore Pakistan

STRESS METER

Project Report submitted to the Mr. Usman Ali,
Department of Electrical Engineering, University of Management and Technology
In partial fulfillment of the requirements for the degree of
Bachelor of Science
In
Electrical Engineering

Sajid Ali 081220-097

Qadeer Imdad 081120-001

Muhammad Husnain Shible 071020-196

ABSTRACT

In continuum mechanics, **stress** is a measure of the internal forces acting within a body. Quantitatively, it is a measure of the average force per unit area of a surface within the body on which internal forces. These internal forces are a reaction to external forces applied on the body act.

The Stress meter allows you access your emotional pain. If the stress is very high, it gives visual indication through LED display along with a warning beep.

STRESS METER

Components Used:

1. IC LM3915 (1 nos.)
2. Touch Pads
3. 9V Battery (1 nos.)
4. LEDs (4 Green, 4 red, 2 Blue)
5. Transistor BC548 (1 nos.)
6. Zener Diode 5.1V, 0.5W (1 nos.)
7. Switch (1 nos.)
8. Piezo Buzzer (1 nos.)
9. Diode 1N4148 (1 nos.)
10. Variable Resistor (1M Ω , 47K Ω)
11. Resistors (47K Ω , 1.2K Ω , 560 Ω , 1K Ω , 470 Ω , 470 Ω)
12. Capacitor 100uF, 16v (2 nos.)
13. Capacitor 10uF, 16v (1 nos.)

OVERVIEW

This stress monitor lets you assess your emotional pain. If the stress is very high, it gives visual indication through a light-emitting diode (LED 5) display along with a warning beep. The gadget is small enough to be worn around the wrist.

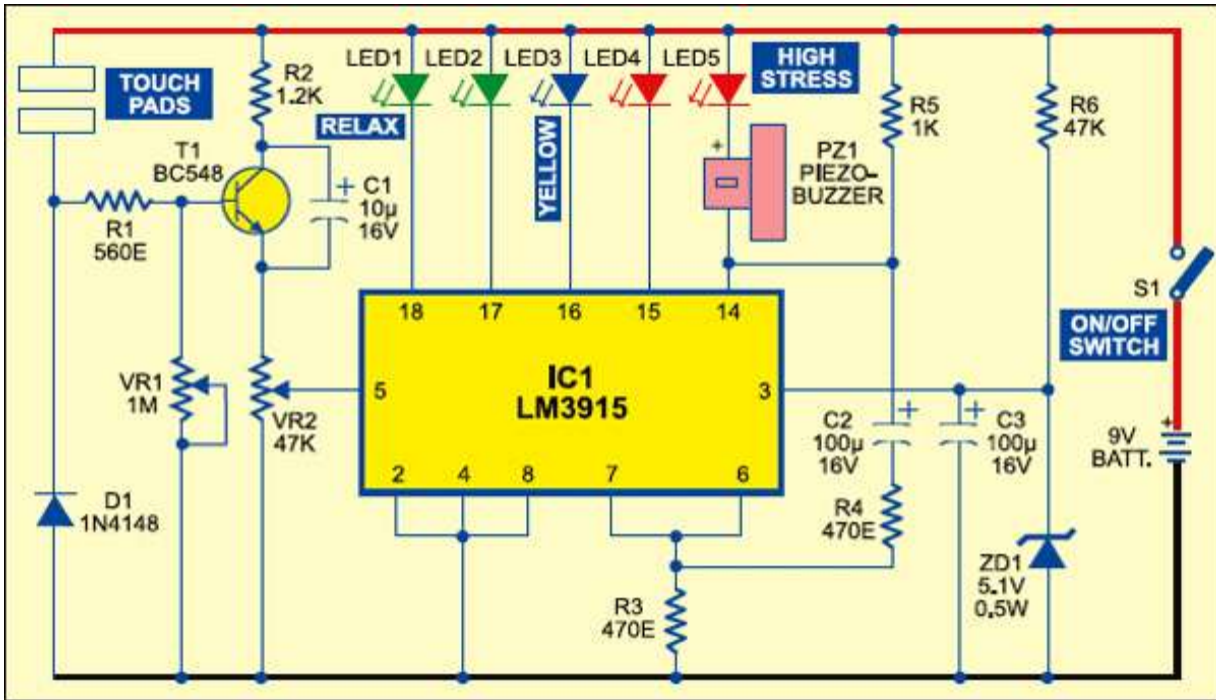

Fig: Component Level Diagram of Stress Meter

WORKING PRINCIPLE OF STRESS METER

The gadget is based on the principle that the resistance of the skin varies in accordance with your emotional states. If the stress level is high the skin offers less resistance, and if the body is relaxed the skin resistance is high. The low resistance of the skin during high stress is due to an increase in the blood supply to the skin. This increases the permeability of the skin and hence the conductivity for electric current.

WORKING OF STRESS METER

This property of the skin is used here to measure the stress level. The touch pads of the stress meter sense the voltage variations across the touch pads and convey the same to the circuit. The circuit is very sensitive and detects even a minute voltage variation across the touch pads.

The circuit comprises signal amplifier and analogue display sections. Voltage variations from the sensing pads are amplified by transistor BC548 (T1), which is configured as a common-emitter amplifier. The base of T1 is connected to one of the touch pads through resistor R1 and to the ground rail through potmeter VR1. By varying VR1, the sensitivity of T1 can be adjusted to the desired level. Diode D1 maintains proper biasing of T1 and capacitor C1 keeps the voltage from the emitter of T1 steady.

The amplified signal from transistor T1 is given to the input of IC LM3915 (IC1) through VR2. IC LM3915 is a monolithic integrated circuit that senses analogue voltage levels at its pin 5 and displays them through LEDs providing a logarithmic analogue display. It can drive up to ten LEDs one by one in the dot/bar mode for each increment of 125 mV in the input. Here, we've used only five LEDs connected at pins 14 through 18 of IC1. LED1 glows when input pin 5 of IC1 receives 150 mV. LED5 glows when the voltage rises to 650 mV and LED5 flashes and piezobuzzer PZ1 beeps when the stress level is high.

Resistors R4 and R5 and capacitor C2 form the flashing elements. Resistor R3 maintains the LED current at around 20 mA. Capacitor C3 should be placed close to pin 3 for proper functioning of the IC. Zener diode ZD1 in series with resistor R6 provides regulated 5V to the circuit.

The circuit can be assembled on a small piece of perforated board. Use transparent 3mm LEDs and a small piezobuzzer for audio-visual indications. Enclose the circuit in a small plastic case with touch pads on the back side. Two self-locking straps can be used to tie the unit around your wrist. After tying the unit around your wrist (with touch pads in contact with the skin), slowly vary VR1 until LED1 glows (assuming that you are in relaxed state). Adjust VR2 if the sensitivity of IC1 is very high. The gadget is now ready for use.

Appendices

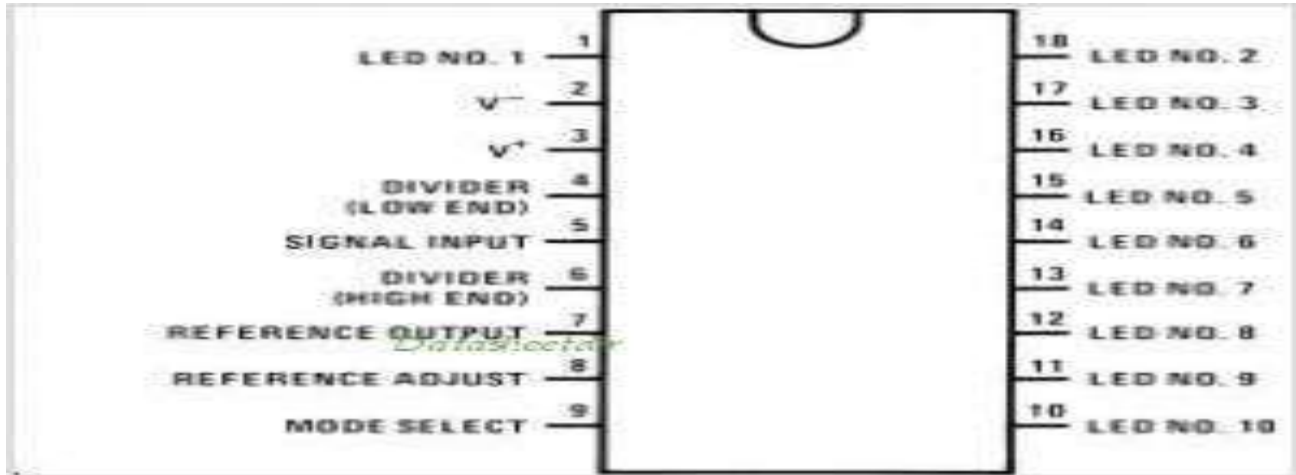

IC (LM 3915) DATASHEET

Helping Link:

http://www.electronicsforu.com/electronicsforu/circuitarchives/view_article.asp?sno=227&article_type=1&title=Stress%20Meter